



CITY OF VICTORVILLE

FIRE PREVENTION DIVISION

14345 Civic Center Drive
Victorville, CA 92392
(760) 955-5233

FIRE PREVENTION STANDARD S-1 HIGH PILE STORAGE/WAREHOUSE BUILDINGS

Standard Number

S-1

Revision Date:
11-30-22

AUTHORITY

California Fire Code Sections 102.9, 103, and section 104.1.1 as amended in section 8.08.04⁽⁵⁾ of the City of Victorville Municipal Code provides that the fire code official of the City of Victorville Fire Department shall have the authority to adopt policies, procedures, rules, and regulations in order to clarify the application of the Fire Code and to specify requirements not specifically provided for by the Fire Code. For further requirements on this subject, see section 508 et. seq. of the California Fire Code. This standard may be modified with the approval of the Fire Code Official.

PURPOSE

The purpose of this standard is to provide the requirements for the protection of high-piled combustible storage (HPS) for a variety of commodities. HPS increases the potential fire hazard within a structure by increasing the vertical height of storage and by providing stability of storage (e.g., rack and automated storage) in a fire situation. The following requirements will ensure that appropriate measures have been taken to provide safety to the public and that the required protection of these commodities has been designed for the appropriate level of hazard as required by the California Fire Code (CFC), Chapter 32. The California Building Code, NFPA 13, City of Victorville Fire Prevention Standards and any other nationally applicable standards, shall still apply.

SCOPE

This standard shall apply to all storage occupancies designated as High Piled Combustible Storage as defined by current California Fire Code (CFC), Chapter 32, the City of Victorville Fire Code and Standards, and any other nationally applicable standards.

DISCLAIMER

These standards may change without notice. Whenever applicable statutes, regulations and standards are updated and adopted, the latest shall apply. Please contact the Victorville Fire Department at (760) 955-5227 to determine if these standards have changed.

These requirements do not exempt any individual from complying with other applicable state, county, or city codes and standards.

SUBMITTALS

At the time of permit application for a high-piled combustible storage permit, plans and specifications, including but not limited to the information listed below, shall be submitted for review and approval. For certain HPS reviews, the services of a design professional familiar with the requirements contained in CFC Chapter 32 may be of great assistance. Once approved, a copy of the approved plan shall be maintained on the premises in an approved location. To determine whether a High-Piled Combustible Storage plan is required to be submitted, please refer to **Attachment S-1.1**.



CITY OF VICTORVILLE

FIRE PREVENTION DIVISION

14345 Civic Center Drive
Victorville, CA 92392
(760) 955-5233

FIRE PREVENTION STANDARD HIGH PILE STORAGE/WAREHOUSE BUILDINGS

Standard Number

S-1

Revision Date:
11-30-22

If a submittal is required, a sets of plans shall be submitted for review and approval, and shall include the requirements of CFC section 3201.3, items 1-14, plus the following:

- 1) A letter of intent containing a detailed description of the products to be stored and the description of all containers, pallets, and packaging materials. This letter must also include a detailed description of the storage methods (racks, shelves, pallets), the total storage area in square feet, maximum storage height, aisle widths, and flue spaces. Within this letter, state that approved high piled storage plans will be maintained on site for the life of the HPS system(s). An authorized officer of the company or business must sign this letter. The letter shall be copied onto the plans.
- 2) A scaled site plan that shows the entire building, including all fire access lanes, fire hydrants, fire department connection, and fire sprinkler risers.
- 3) The designation of a high-piled combustible storage area, or portion thereof intended for storage of a different commodity class, shall be based on the highest hazard commodity class stored, unless an engineering analysis has been submitted for review and approval.
- 4) Note: In buildings with multi-tenant spaces, the plan shall show if the tenant spaces within the building are separated by a one-hour fire barrier, or that the adjacent tenant(s) does not have HPS. In the event that the adjacent tenant(s) has HPS and are not separated by a one-hour fire barrier per CBC Section 707, the aggregate of all areas of HPS within the building shall be used for the application of Table 3206.2. Additionally, the provisions of CFC 3206.3.2 for multiclass high-piled combustible storage areas shall apply.
- 5) The sprinkler design requirements based on commodity type, aisle width, and sprinkler temperature rating as outlined in NFPA 13 (e.g., .45/3000 with 286-degree heads). A complete sprinkler design shall be submitted under a separate permit by a C16 licensed sprinkler contractor.
- 6) The location, make, model, type, and automatic link temperature of any automatic/manual release smoke/heat vents.
- 7) Mechanical Smoke Exhaust. If the building is equipped, the plans shall show location, size, operation, supply air, interlocks, wiring and control.
- 8) Fire control room location.
- 9) Pallet/commodity stop details for maintaining the required flue space (**See Diagram S-1.1**).

DEFINITIONS

COMMODITY ANALYSIS- A questionnaire, which is required to be answered pertaining to the identity and description of stored materials. This standardized format will provide vital information to help determine the required fire protection needed for warehouse business. This information shall be filed, as a record of the business, and as part of the application permit. (**See Attachment S-1.1**)



CITY OF VICTORVILLE

FIRE PREVENTION DIVISION

14345 Civic Center Drive
Victorville, CA 92392
(760) 955-5233

FIRE PREVENTION STANDARD HIGH PILE STORAGE/WAREHOUSE BUILDINGS

Standard Number

S-1

Revision Date:
11-30-22

FIRE CONTROL ROOM- A central control station room for fire department operations housing the fire alarm control panel, fire protection systems site map, mechanical exhaust controls, etc.

ENCAPSULATED STORAGE- Encapsulated commodities are products wrapped on six sides with plastic. Sprinkler water is not able to penetrate into the commodity if it is encapsulated. Typically, encapsulated products require a higher level of fire sprinkler protection.

EXPANDED PLASTIC- A foam or cellular plastic material having a reduced density based on the presence of numerous small cavities or cells dispersed throughout the material.

EXTRA-HIGH-RACK COMBUSTIBLE STORAGE- Storage on racks of Class I, II, III or IV commodities which exceed 40 feet in height and storage on racks of high-hazard commodities which exceed 30 feet in height.

HIGH-PILED COMBUSTIBLE STORAGE- The storage of combustible materials in closely packed piles or combustible materials on pallets, in racks, or on shelves where the top of storage is greater than 12 feet in height. Where required by the fire code official, high-piled combustible storage also includes certain high-hazard commodities, such as rubber tires, Group A plastics, flammable and combustible liquids, idle pallets, and similar commodities where the top of storage is greater than 6 feet in height.

HIGH-PILED STORAGE AREA- An area within a building which is designated, intended, proposed or actually used for high-piled combustible storage, including operating aisles.

NON-ENCAPSULATED STORAGE- Non-encapsulated commodities are products which may be wrapped on four or five sides, with the top remaining open to permit fire sprinkler water to penetrate within the pile.

OPEN RACK- Racks without shelving or with shelving in racks that are fixed in place with shelves having a solid surface and shelf area equal or less than 20 sq ft or with shelves having a wire mesh, slatted surface, or other material with openings representing at least 50 percent of the shelf area including the horizontal area of rack members and where the flue spaces are maintained.



CITY OF VICTORVILLE

FIRE PREVENTION DIVISION

14345 Civic Center Drive
Victorville, CA 92392
(760) 955-5233

FIRE PREVENTION STANDARD HIGH PILE STORAGE/WAREHOUSE BUILDINGS

Standard Number

S-1

Revision Date:
11-30-22

PALLET/COMMODITY STOPS- A method of restricting the positioning of pallets on a rack so as to not obstruct the required longitudinal flue space. **(See Diagram S-1.1).**

RACK STORAGE- A combination of vertical, horizontal, and diagonal members that support stored materials. Racks can be fixed or portable.

SHELF STORAGE- Storage on structures up to and including 30in. deep and separated by aisles at least 30 in. wide. For larger shelves and other storage arrangements see Rack Storage.

SOLID SHELVING- Shelving that is fixed in place, slatted, wire mesh, or other type of shelves located within racks. The area of a solid shelf is defined by perimeter aisle or flue space on all four sides or by the placement of loads that block openings that would otherwise serve as the required flue spaces. Solid shelves having an area equal to or less than 20 square feet are defined as open racks. Shelves of wire mesh, slats, or other materials more than 50 percent open and where the flue spaces are maintained are defined as open racks.

GENERAL

- 1) Fire-protection and life safety features for high-piled storage areas shall be in accordance with the currently adopted CFC Chapter 32, the current edition of NFPA 13 and other nationally recognized standards approved.
- 2) Plans and specifications shall be submitted to City of Victorville Fire Prevention Division. A CFC permit is required when a building or portion thereof is used for high-piled storage that exceeds 500 square feet in area. All permits will be issued following plan approval and completion of corresponding inspections of the HPS installation. CFC permits for high-piled storage shall be renewed annually, or upon a change in commodity or configuration. A previously approved HPS plan may be used for renewing permits, unless changes in the storage configuration and/or commodity result in the need for a new plan review, update and/or approval.

TECHNICAL ASSISTANCE

Due to the complex building design requirements specified within the CFC and adopted standards, the Fire Code Official is authorized to require a technical report and plans with the stamp and signature of a professional engineer, and it is often necessary to obtain the service of a fire protection design professional to assist with developing a protection scheme that meets the requirements of both the California Building and Fire Codes. This requirement will be determined by the plans reviewer and/or if, the commodities being stored are High Hazard or Group "A" plastics or similar commodities.

FIRE CONTROL ROOM

A central control station room for fire department operations shall be provided. The location and accessibility of the central control station room shall be approved by the Fire Code Official. The central control station room shall be separated from the remainder of the building by not less than a one-hour fire-resistive occupancy separation. When the building is required to have a fire pump to



CITY OF VICTORVILLE

FIRE PREVENTION DIVISION

14345 Civic Center Drive
Victorville, CA 92392
(760) 955-5233

FIRE PREVENTION STANDARD HIGH PILE STORAGE/WAREHOUSE BUILDINGS

Standard Number

S-1

Revision Date:
11-30-22

maintain the required fire flow, the fire control room shall be located adjacent to the fire pump house. The room shall be a minimum of 96 square feet with a minimum dimension of 8 feet (2438 mm). It shall contain the following as a minimum:

- 1) The fire alarm control panel and system site map. The site map is to be a plexiglass floor plan with LED lights to indicate the locations and status (alarm, trouble, operating, etc) of all sprinkler risers, fire suppression water valves, mechanical smoke removal systems, roll down fire doors, etc.
- 2) Status indicators and controls for mechanical smoke removal system.
- 3) Sprinkler valve and water-flow detector display panels.
- 4) Schematic building plans indicating the typical floor plan, means of egress, fire- protection systems, firefighting equipment and access.
- 5) Other fire-protection equipment and system controls as required by the Fire Code Official.
- 6) Lighting for the central control station shall have emergency lighting powered by the standby electrical system.
- 7) Provide signage on the door stating "FIRE CONTROL ROOM". Letters are to be minimum 4" high with 1: stroke, red on a white background.
- 8) The Knox lockbox for the building shall be located at the fire control room.

SPRINKLER SYSTEMS

- 1) Fire sprinkler systems shall be designed in accordance with the current edition of NFPA 13 and Fire Dept Standard F-1 to protect the commodity class of the materials being stored.
- 2) Where more than two sprinkler systems protect the high pile storage area, the components of the systems shall be individually identified to allow easy recognition of the system in question. Any method of identification approved by the Fire Code Official may be used (colored tapes, paint, numbers, letters, etc). At a minimum, the following components shall be identified: risers, cross mains, branch line tails, fire hose connections.

BUILDING ACCESS

- 1) Where building access is required by the fire code, fire apparatus access roads shall be provided to within 150 feet of all portions of the exterior walls of the building used for high-piled storage.
- 2) Exception: Where fire apparatus access roads cannot be installed because of topography, railways, waterways, non-negotiable grades or other similar conditions, the Fire Code Official is authorized to require additional fire protection.
- 3) Where access doors are required, fire department access doors shall be provided in each 100 linear feet, or fraction thereof, of the exterior walls which face the required fire apparatus access roads. Access doors shall not be less than 3 feet in width and 6 feet 8 inches in height. Roll-up doors shall not be used unless approved by the Fire Code Official.
- 4) Access doors shall be numbered. Numbers shall be minimum three (3) inch, contrasting color, located in the top half of the door, inside and outside of the door.



CITY OF VICTORVILLE

FIRE PREVENTION DIVISION

14345 Civic Center Drive
Victorville, CA 92392
(760) 955-5233

FIRE PREVENTION STANDARD HIGH PILE STORAGE/WAREHOUSE BUILDINGS

Standard Number

S-1

Revision Date:
11-30-22

- 5) Where fire department hose connections are required in the building, the doors that provides access to these connections shall have a blue reflector (hydrant marker) attached to the wall to identify the access to the hose connection (see Standard W-2 for specifications of the hydrant markers).

FLUE SPACES

- 1) Flue spaces shall be provided in accordance with Table 3208.3. Required flue spaces shall be maintained. Single and double-row racks shall be equipped with a transverse flue space. A mechanical means shall be provided to maintain the transverse flue space at the uprights. Transverse flue spaces between uprights shall be marked with a 3 or 6 inch yellow strip on the load beam with words in red that read, "Keep Clear," as indicated below. Durable vinyl tape, paint, or other methods as approved by the Fire Code Official may be used.
- 2) Double-row racks shall be equipped with a pallet/commodity stop along the longitudinal flue space at each level. The stop along the longitudinal flue space shall be steel or other ferrous material $\frac{1}{4}$ " thick and, in the mounted position, shall extend a minimum of 4 inches above the shelf or cross member, or other method (i.e., 12-gauge chain link) approved by the fire code official (**See Diagram S-1.1**).
- 3) In double-row racks, where products are hand-stacked, chain link shall be securely attached to the rear of both racks. The chain link shall be a minimum of 12 gauge. Attachment method shall be as approved by the fire code official.

NOTE: Regardless of the design of the pallet stop, the longitudinal flue space shall be measured from the back of the pallet stop to the back of the opposing pallet stop. Transverse flue space is measured as the distance between the loads, not the distance between the racks. A flue space's net width is a measure of its gross width minus any horizontal obstructions, such as rack uprights, located within the flue space. In other words, a rack upright (typically 3 in. wide) is not considered a flue space, due to the cross bracing used.

MECHANICAL SMOKE REMOVAL

Mechanical smoke removal systems shall be provided for buildings protected by ESFR sprinkler systems as required by the Fire Code Official. The mechanical smoke removal systems shall meet the requirements of the Fire Code and the following:

- 1) Override controls for the smoke exhaust system shall be located in the fire control room. Controls shall allow the fire personnel to turn each fan on or off individually, with operational status indicators.
- 2) Maximum spacing for fans: within 150' of perimeter walls, no greater than 250' between fans.
- 3) Fans are to be evenly spaced throughout the roof area.



CITY OF VICTORVILLE

FIRE PREVENTION DIVISION

14345 Civic Center Drive
Victorville, CA 92392
(760) 955-5233

Standard Number

S-1

Revision Date:
11-30-22

FIRE PREVENTION STANDARD HIGH PILE STORAGE/WAREHOUSE BUILDINGS

DIAGRAM S-1.1 PALLET STOP DETAILS

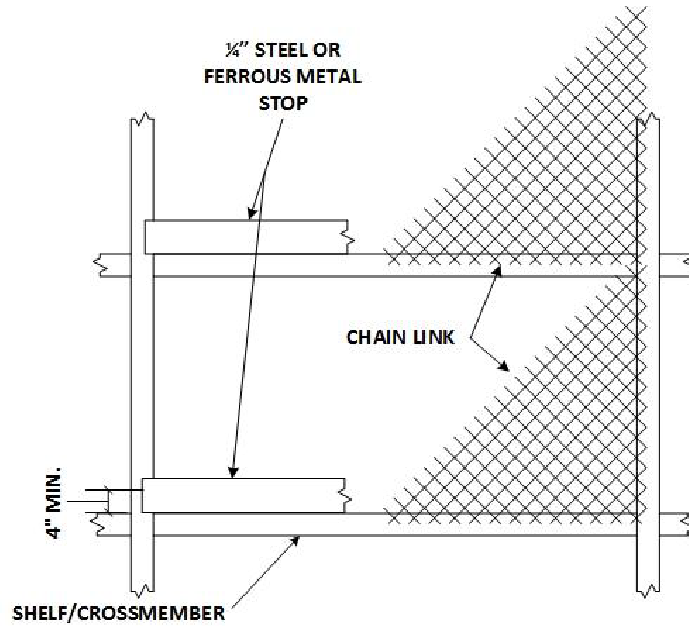

SIDE VIEW

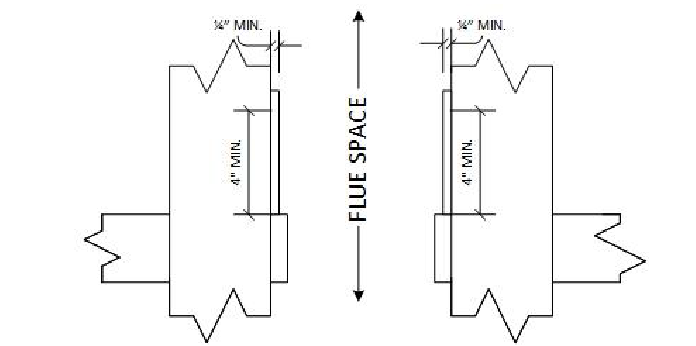



CITY OF VICTORVILLE

FIRE PREVENTION DIVISION

14345 Civic Center Drive
Victorville, CA 92392
(760) 955-5233

Standard Number

S-1

Revision Date:
11-30-22

FIRE PREVENTION STANDARD HIGH PILE STORAGE/WAREHOUSE BUILDINGS

ATTACHMENT S-1.1

High Pile Storage (HPS) Required Information

The following information shall be completed and copied onto the HPS plans for all projects within City of Victorville jurisdiction:

Commodity Classification: I II III IV High Hazard Group A plastic Commodity

description: _____

Cartoned Free flowing Non-expanding Encapsulated Non-encapsulated
Other _____

The area designated in the building and used for high piled storage is _____ square feet.

CLASS _____ commodity, _____ sq ft.

CLASS _____ commodity, _____ sq ft.

CLASS _____ commodity, _____ sq ft.

The maximum permitted storage height (solid pile _____ rack _____)

The following storage methods are employed at this facility:

Solid pile storage Palletized Single row rack Double row rack Multi-row rack

Other _____

Rack storage shelf: N/A Load beam only Wire mesh Wood slates Plywood

Other (Describe): _____

Minimum distance between top of storage and sprinkler _____

Smoke vents required: Yes No

Operation of smoke vents (if applicable)

Manual Automatic via fusible link which releases at _____ degree F.

(Note: New installations require manual & automatic release)

Inspection Report shall indicate which vents were tested

Draft Curtains Required? Yes No

The overhead fire sprinkler system utilizes the following heads:

ESFR: K _____ at _____ PSI with _____ degrees F heads



CITY OF VICTORVILLE

FIRE PREVENTION DIVISION

14345 Civic Center Drive
Victorville, CA 92392
(760) 955-5233

Standard Number

S-1

Revision Date:
11-30-22

FIRE PREVENTION STANDARD HIGH PILE STORAGE/WAREHOUSE BUILDINGS

Standard Coverage Heads: K _____ Pendant ____ Upright _____ degrees F with a density of _____ gpm over _____ square feet spaced at a maximum of _____ square feet per fire sprinkler

The fire sprinkler system density and area of application for the storage area is _____ gpm over _____ square feet

In-rack sprinklers required? Yes ____ No ____

There is/are _____ level(s) of in-rack fire sprinkler protection.

The aisles between the racks shall be maintained at _____ feet.

Fire Doors required? Yes ____ No ____

Flue Spaces required? Yes ____ No ____

Flue space between racks shall be maintained a minimum of:

Transverse _____" clear. Must be vertically aligned (for storage >25')

Longitudinal _____" clear

Column protection required? Yes ____ No ____

Pallet Stops Required? Yes ____ No ____

Longitudinal pallet stop configuration:

Chain Link Roll Form "C" Channel Transverse

Flue Pallet Stop configuration:

Mechanical means (flue keepers, etc.) Load beam markings "Keep Clear"

Hand Stack? Yes ____ No ____ # of tiers: _____ Chain link required? Yes ____ No ____

Wooden palletized storage shall not exceed 5 feet? Yes ____ No ____

Storage configuration and height delineated by indication on floor or walls. Yes ____ No ____

Additional conditions
