



CITY OF VICTORVILLE

FIRE PREVENTION DIVISION

14345 Civic Center Drive
Victorville, CA 92392
(760) 955-5233

Standard Number

G-3

Revision Date:
11-5-25

FIRE PREVENTION STANDARD

G-3 PALLET REFURBISHING AND STORAGE YARDS

AUTHORITY

California Fire Code Sections 102.9, 103, and section 104.1.1 as amended in section 8.08.04⁽⁵⁾ of the City of Victorville Municipal Code provides that the fire code official of the City of Victorville shall have the authority to adopt policies, procedures, rules, and regulations in order to clarify the application of the Fire Code and to specify requirements not specifically provided for by the Fire Code. For further requirements on this subject, see section 508 et. seq. of the California Fire Code. This standard may be modified with the approval of the Fire Code Official.

PURPOSE

The purpose of this standard is to provide minimum requirements for fire access, water supply and other general safety requirements for the outside storage of combustible pallets.

SCOPE

This standard applies to the outdoor storage of combustible idle pallets at pallet manufacturing, refurbishing, or storage facilities, and to the incidental storage of combustible pallets at commercial and industrial facilities.

DISCLAIMER

These standards may change without notice. Whenever applicable statutes, regulations, and standards are updated and adopted, the latest shall apply. Please contact the Victorville Fire Prevention Division at (760) 955-5227 to determine if these standards have changed. These requirements do not exempt any individual from complying with other applicable state, county, or city codes and standards.

SUBMITTALS

For new facilities, the owner shall provide a plot plan containing the following information:

- 1) All pages of plans shall have a three-inch (3) by three-inch (3) box labeled "FOR FIRE DEPARTMENT USE ONLY" located in the bottom right corner of every page for approval stamp.
- 2) Provide a scaled site plan or plot plan the following information at a minimum:
 - a. Location of all fire apparatus access roads and fire apparatus turnarounds for dead-end roadways.
 - b. Dimensions indicating width, length, and radii of all turns for all fire access roads.
 - c. Surfacing specifications of fire access roads, including pavement type and thickness. May also require a report from a registered engineer for certain conditions.



CITY OF VICTORVILLE

FIRE PREVENTION DIVISION

14345 Civic Center Drive
Victorville, CA 92392
(760) 955-5233

Standard Number

G-3

Revision Date:
11-5-25

FIRE PREVENTION STANDARD PALLET REFURBISHING AND STORAGE YARDS

- d. Locations of any types of obstructions to fire access roads. (See also VFPD standard A-3)
- e. The locations of all temporary and permanent structures, log decks, firewood stacks and any other combustibles.
- f. Location of all fire protection water sources (hydrants, tanks, etc.).
- g. Locations of all parking areas, landscaping areas, walkways, and any other adjacent areas.
- h. Location of significant hazards (i.e., flammable or combustible liquids, hazardous materials, or LPG tanks).

3) Planning Department approval letter

DEFINITIONS

Pallet - a portable platform for handling, storing, or moving materials and packages (as in warehouses, factories, or vehicles)

Stack - Single pallets placed horizontally on top of one another in an orderly and stable manner.

Pile - A group of single pallet stacks clustered closely together within 6 inches of each other.

Fire Department Access Road - A road that provides fire apparatus access from a fire station to a facility, building or portion thereof. This is a general term inclusive of all other terms such as fire lane, private street, parking lot lane and access roadway. Access roads shall be a minimum of 26' in width with an unobstructed clear height of 14'6".

Fire Flow - The flow rate of a water supply, measured at 20 psi residual pressure that is available for firefighting.

Permit - An official document or certificate issued by the authority having jurisdiction which authorizes performance of a specific activity.

GENERAL

- 1) Pallets stored outside shall be in accordance with the requirements of this Standard.
- 2) Pallets stored inside of a building shall be in accordance with the provisions of NFPA 13, currently adopted California Fire Code.
- 3) Pallets shall be stored in stacks in an orderly, stable manner and shall not exceed sixteen (16) feet in height. In areas of the county or in cities where zoning regulations require lower storage heights or screening, these shall be complied with.
- 4) Individual stacks of pallets may be clustered into piles not to exceed twenty (20) feet in width and twenty (20) feet in length and shall not exceed 6,400 cubic feet in volume. (See DIAGRAM G-3.1)



CITY OF VICTORVILLE

FIRE PREVENTION DIVISION

14345 Civic Center Drive
Victorville, CA 92392
(760) 955-5233

Standard Number

G-3

Revision Date:
11-5-25

FIRE PREVENTION STANDARD

PALLETT REFURBISHING AND STORAGE YARDS

- 5) Pallet piles shall be separated by a minimum of twenty (20) feet from other piles, structures, or other exposures. These areas shall remain clear of obstructions, storage and equipment at all times. In areas where zoning regulations require greater setbacks or screen walls, these shall be complied with.
- 6) Pallet manufacturing, refurbishing or other processing areas shall meet the fire protection requirements in the Fire Code and adopted standards. A minimum 4A:40BC Portable fire extinguisher shall be provided within seventy-five (75) feet of any pallet stack or manufacturing area.
- 7) 7) Welding or cutting operations shall not be conducted without first obtaining a "hot works" permit from the VFPD. Clearance to ignition sources shall be maintained from all combustibles at a minimum of twenty-five (25) feet, and an approved fire watch shall be in place during hot work activity and for thirty (30) minutes after the conclusion of such work; or as specified by the Fire Code.
- 8) A minimum of one "No Smoking" sign shall be posted at the facility, and additional signs in processing areas and other areas may be required where deemed appropriate by the fire code official. "Designated Smoking Area" signs shall be posted, if necessary, in an area a minimum of twenty-five (25) feet away from combustibles.
- 9) Flammable and combustible fuels for use in vehicles shall be stored in approved underground or approved aboveground vaulted tanks. These tanks shall be inspected and approved under a separate permit from the VFPD.
- 10) If fire suppression activities are required, the business owner will be responsible for any and all costs that may occur for fire suppression efforts.

FIRE ACCESS

- 1) Fire apparatus access roads shall be designed, constructed, and maintained in accordance with VFPD Standard A-1, A-2, A3 and the currently adopted California Fire Code section 503.
- 2) Fire access lanes of a minimum twenty-six feet (26') in width shall be required along the interior perimeter of the yard adjacent to the property line.
- 3) Fire apparatus access roads shall not be obstructed by any vehicles or storage at any time.
- 4) A durable marking system shall be used to indicate the designated area for pallet stacks and fire access roads.

WATER SUPPLY

- 1) In areas served by a water purveyor, an approved water supply with a minimum fire flow of



CITY OF VICTORVILLE

FIRE PREVENTION DIVISION

14345 Civic Center Drive
Victorville, CA 92392
(760) 955-5233

Standard Number

G-3

Revision Date:
11-5-25

FIRE PREVENTION STANDARD PALLET REFURBISHING AND STORAGE YARDS

2,250 GPM at 20 psi for a two (2) hour duration shall be provided from fire hydrants (s) and shall be installed in accordance with VFPD Standard W-2 and other applicable standards.

- a. Required fire flow has been determined by combining the max pile square footage of four hundred (400) square feet with the clear aisle spacing of twenty (20) feet around the entire pile (6,400 sf). This method ensures the appropriate fire flow is available for fire suppression.
- 2) In areas without a water purveyor capable of supplying the required fire flow, an approved fire protection water system providing the required fire flow shall be installed in accordance with the fire code, VFPD Standard W-1 and other applicable standards.
- 3) Fire hydrants shall be spaced in accordance with the Victorville Fire Code and VFPD Standard W-2, at each entrance to the property, and where required along fire access roads, and in locations acceptable to the Fire Department.



CITY OF VICTORVILLE

FIRE PREVENTION DIVISION

14345 Civic Center Drive
Victorville, CA 92392
(760) 955-5233

Standard Number

G-3

Revision Date:
11-5-25

FIRE PREVENTION STANDARD PALLET REFURBISHING AND STORAGE YARDS

DIAGRAM G-3.1: STORAGE ARRANGEMENT WITHIN PALLET YARDS

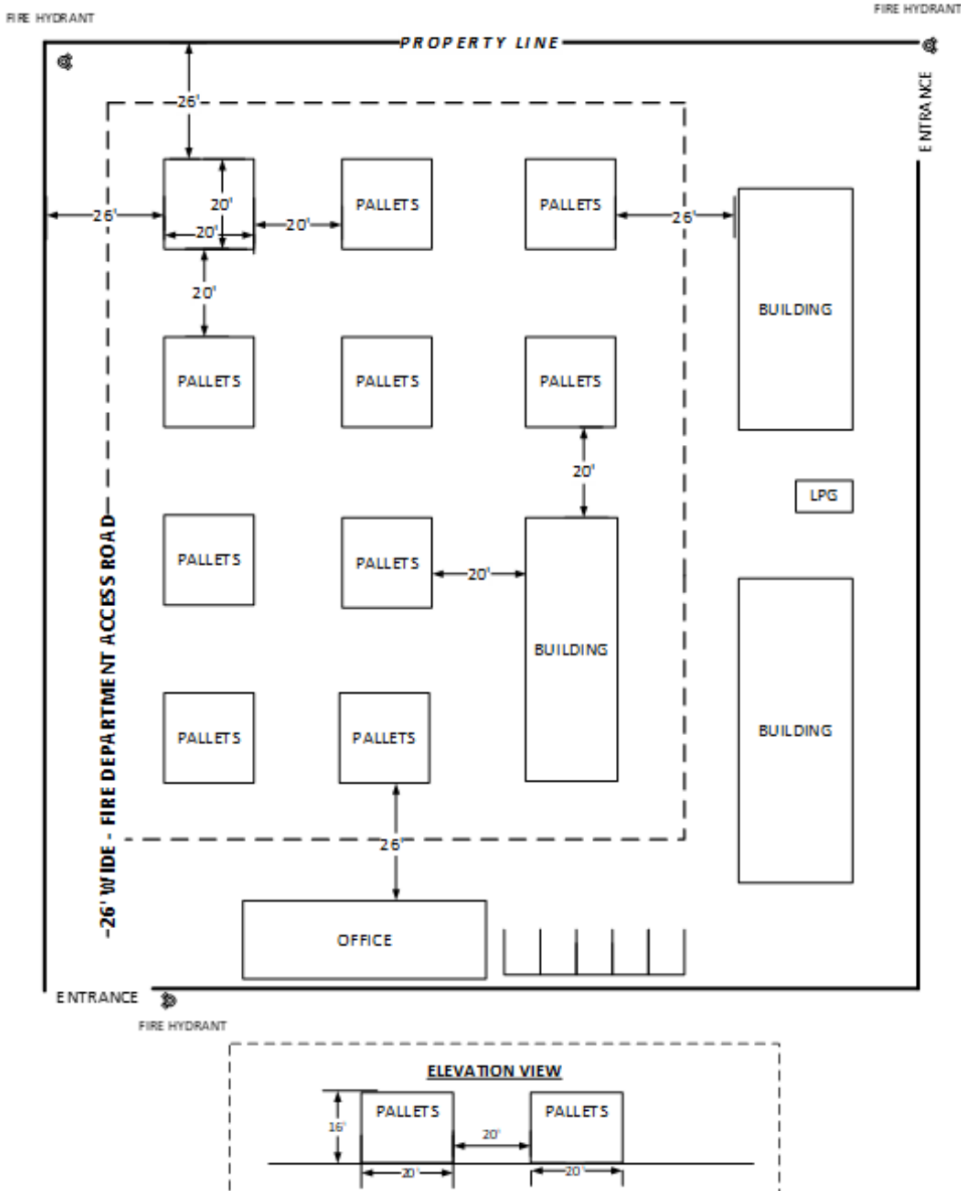



CITY OF VICTORVILLE

FIRE PREVENTION DIVISION

14345 Civic Center Drive

Victorville, CA 92392

(760) 955-5233

FIRE PREVENTION STANDARD PALLET REFURBISHING AND STORAGE YARDS

Standard Number

G-3

Revision Date:

11-5-25